

REB 5

509 703

UNIT 'U'

FOUNDATION PLAN

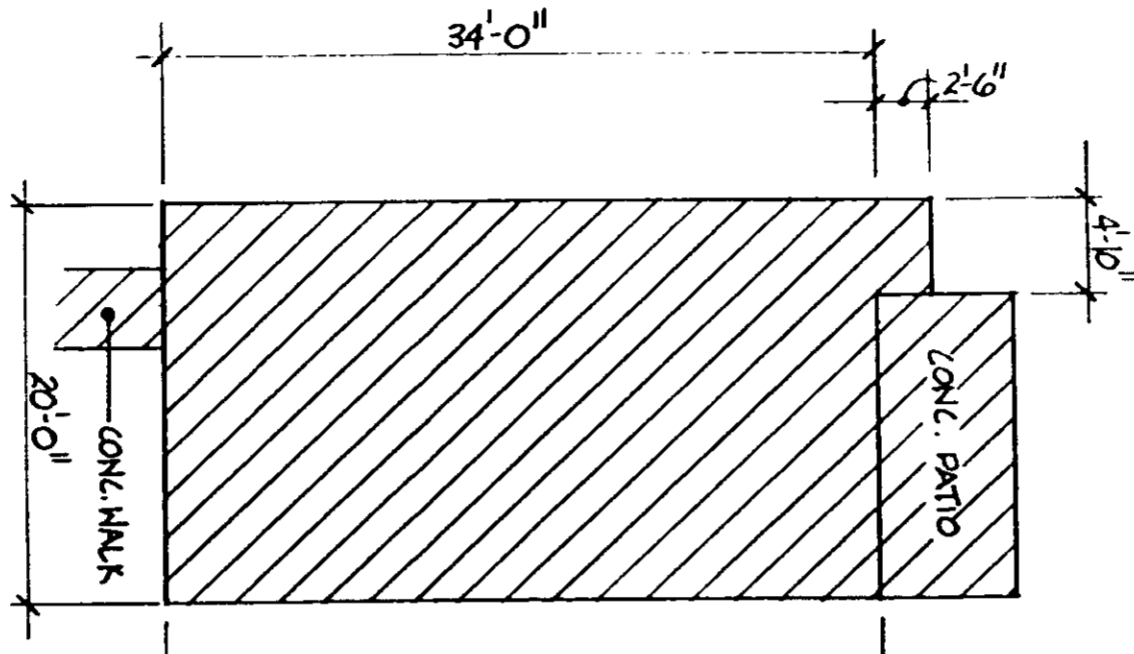

FIRST FLOOR PLAN

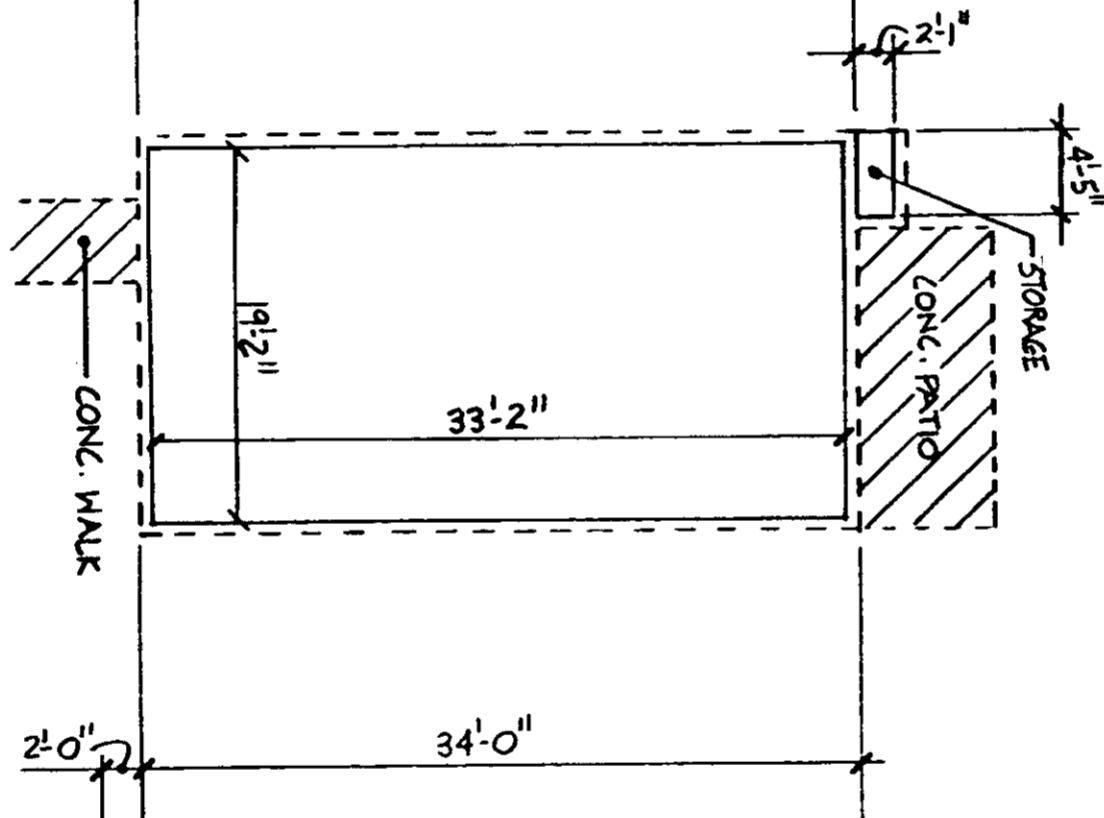

SECOND FLOOR PLAN

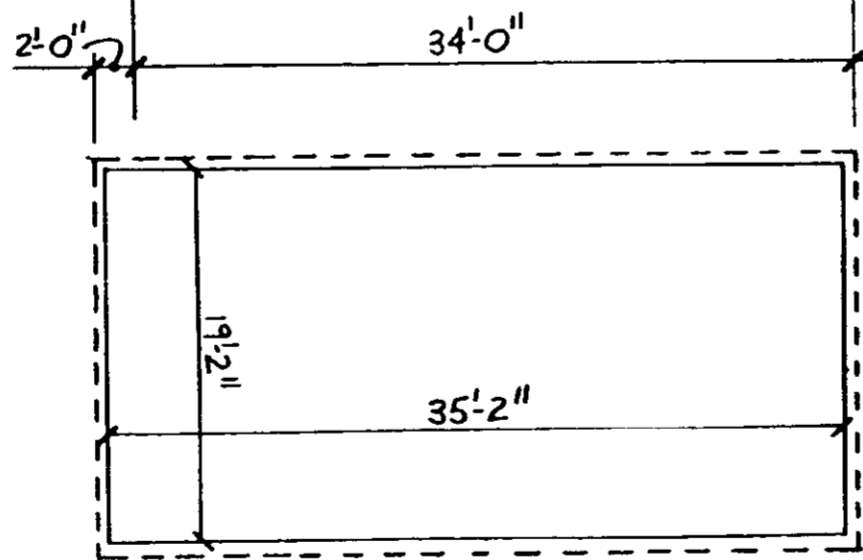

LEGEND

—	UNIT BOUNDARY
- - -	GENERAL BOUNDARY
	UNITED FRONT
	UNITED REAR
	UNITED SIDE
	UNITED CORNER
	UNITED ENTRANCE
	UNITED EXIT
	UNITED STAIR
	UNITED ELEVATOR
	UNITED MECHANICAL
	UNITED ELECTRICAL
	UNITED PLUMBING
	UNITED GAS
	UNITED WATER
	UNITED SEWER
	UNITED RADIANT HEATING
	UNITED AIR CONDITIONING
	UNITED FIRE PROTECTION
	UNITED SOUND ATTENUATION
	UNITED VIBRATION CONTROL
	UNITED LIGHTING
	UNITED SECURITY
	UNITED ACCESSIBILITY
	UNITED SUSTAINABILITY
	UNITED WELL-BEING
	UNITED COMMUNITY
	UNITED CULTURE
	UNITED HISTORY
	UNITED HERITAGE
	UNITED IDENTITY
	UNITED BELONGING
	UNITED WELLNESS
	UNITED RESILIENCE
	UNITED ADAPTABILITY
	UNITED FLEXIBILITY
	UNITED INCLUSIVITY
	UNITED EQUITY
	UNITED JUSTICE
	UNITED DIGNITY
	UNITED RESPECT
	UNITED TOLERANCE
	UNITED EMPATHY
	UNITED COMPASSION
	UNITED KINDNESS
	UNITED GENTLENESS
	UNITED PATIENCE
	UNITED SELF-CONTROL
	UNITED FAITH
	UNITED HOPE
	UNITED LOVE

I, M. WILLIAM BAKER, JR., HEREBY CERTIFY THAT THE WITHIN FLOOR PLANS ARE TRUE AND CORRECT TO THE BEST OF MY KNOWLEDGE.  
M. WILLIAM BAKER, JR.  
SC REGISTRATION # 10888



4328 RV.21